

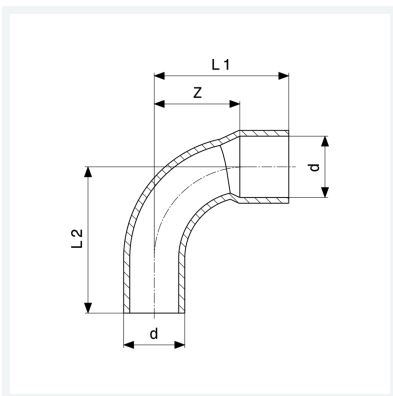

Bogen 90°
- Lötanschluss, Einsteckende
Modell 95001A

Artikel 101 510



Eigenschaften

| | | |
|----------------------|------------------------|-------|
| Gütesicherung Cu | Cu | ✓ |
| Rohraußendurchmesser | d | 12 |
| Z-Maß | Z | 14 mm |
| Länge 1 | L1 | 23 mm |
| Länge 2 | L2 | 25 mm |
| Gewicht | 11,24 g | |
| Volumen | 16,576 cm ³ | |
| Werkstoff | Kupfer | |